

NOTES:

- 1 STANDARD TOE-IN IS BETWEEN 0° TO 0°
STANDARD CAMBER IS BETWEEN -0.6° TO -1.4°
- 2 TANDEM TOE-IN IS 0°
TANDEM CAMBER IS BETWEEN -0.6° TO -1.4°

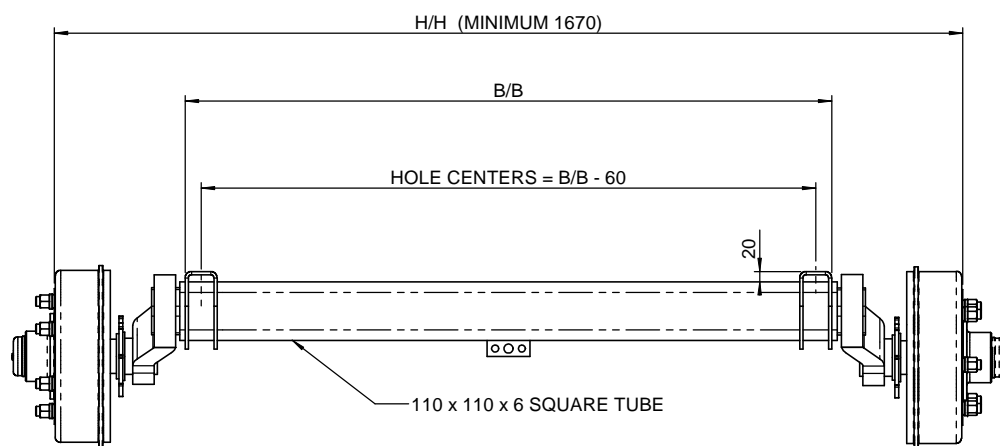
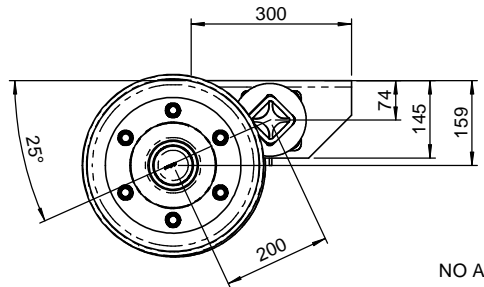
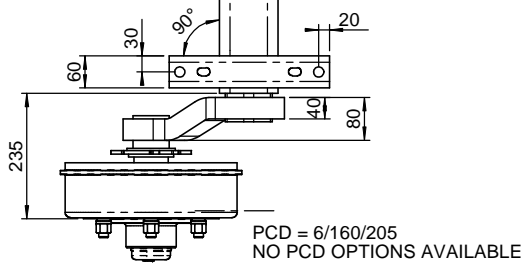

© COPYRIGHT BURQUIP INTERNATIONAL (Pty) Ltd				TITLE:	
H.M. 2008-10-10				ASSUME A TOLERANCE OF ±1mm FOR DIMENSIONS WITHOUT TOLERANCES ALL DIMENSIONS IN mm UNLESS OTHERWISE SHOWN	
H.M. 2008-05-23				PRODUCT: ARC3000/3500-1	
H.M.				SCALE: 1:10 SHEET: A3	
BY				DRAWN BY: HILTON MILLWARD	
DATE				DATE: 20017-09-06	

BURQUIP

P3	CHANGED HUBFACE TO TUBE DISTANCE FROM 220mm TO 235mm
P2	CORRECTED HUBFACE TO TUBE DISTANCE
P1	RELEASED
REV	DESCRIPTION OF CHANGE

DRAWING NO. ARC3000-3500-1		REV P3
SHEET 1 of 1		