

- NOTES:
- STANDARD TOE IN IS BETWEEN 0.2° & 0.6°
 STANDARD CAMBER IS BETWEEN -0.6° TO -1.4°
 - TANDEM TOE IN IS 0°
 TANDEM CAMBER IS BETWEEN -0.6° TO -1.4°

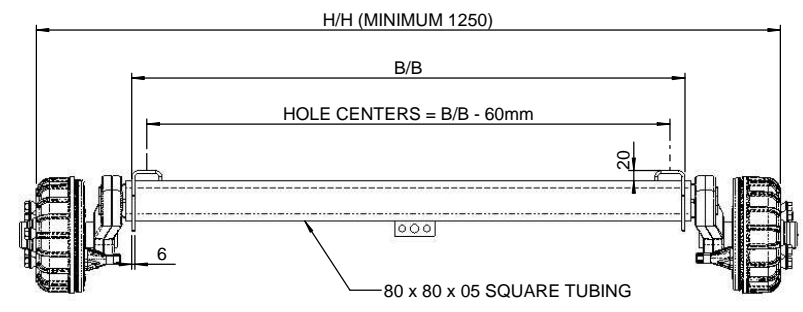

© COPYRIGHT BURQUIP INTERNATIONAL (Pty) Ltd

TITLE: **ARC1200/1600-1**

BURQUIP

P2	CHANGED BRAKE DRUM CODE FROM HBB200 SERIES TO HBB200B SERIES
P1	RELEASED

H.M.	H.M.	2010-02-19
H.M.	H.M.	
ZONE	AUTH NO.	BY
		DATE

ASSUME A TOLERANCE OF ±1mm FOR DIMENSIONS WITHOUT TOLERANCES ALL DIMENSIONS IN mm UNLESS OTHERWISE SHOWN

PRODUCT:	ARC1200/1600-1
SCALE:	1:10
SHEET:	A3
DRAWN BY:	HILTON MILLWARD
DATE:	2007-06-26

DRAWING NO.	ARC1200-1600-1	SHEET	1 of 1	REV	P2
-------------	-----------------------	-------	--------	-----	-----------