

- NOTES:
- 1 STANDARD TOE IN IS BETWEEN 0.2° TO 0.6°
STANDARD CAMBER IS BETWEEN -0.6° TO -1.4°
 - 2 TANDEM TOE IS 0°
TANDEM CAMBER IS BETWEEN -0.6° TO -1.4°

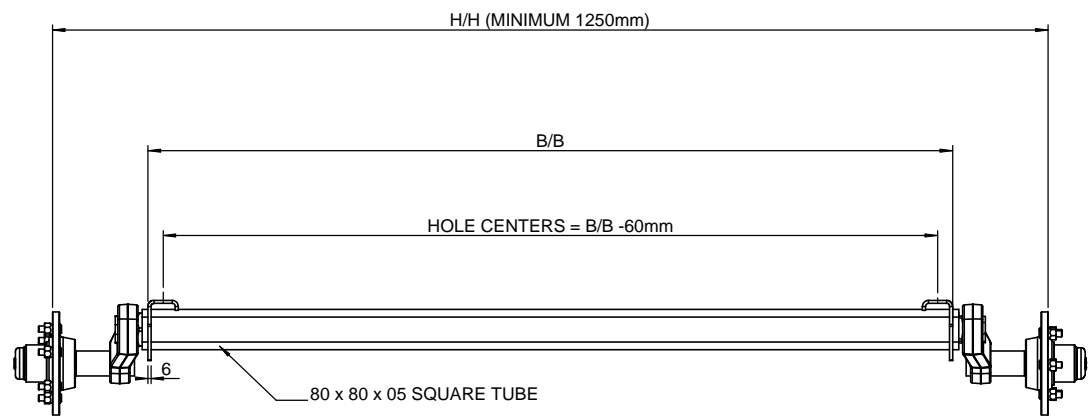

© COPYRIGHT BURQUIP INTERNATIONAL (Pty) Ltd

TITLE:

PRODUCT: **AR1300/1800-1**



P2	CHANGED HUB CODE FROM HUB1250 SERIES TO HUB0800B SERIES	H.M.	H.M.	2010-02-19	
P1	RELEASED	H.M.	H.M.		
REV	DESCRIPTION OF CHANGE	ZONE	AUTH NO.	BY	DATE

ASSUME A TOLERANCE OF ±1mm FOR DIMENSIONS WITHOUT TOLERANCES ALL DIMENSIONS IN mm UNLESS OTHERWISE SHOWN

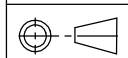

SCALE: 1:10 SHEET: A3
DRAWN BY: HILTON MILLWARD
DATE: 2008-08-01

DRAWING NO. **AR1300-1800-1** SHEET 1 of 1 REV **P2**