

STANDARD ANGLE 25°
OPTIONAL 45°, 15°, 0°
-45°, -25°, -15°

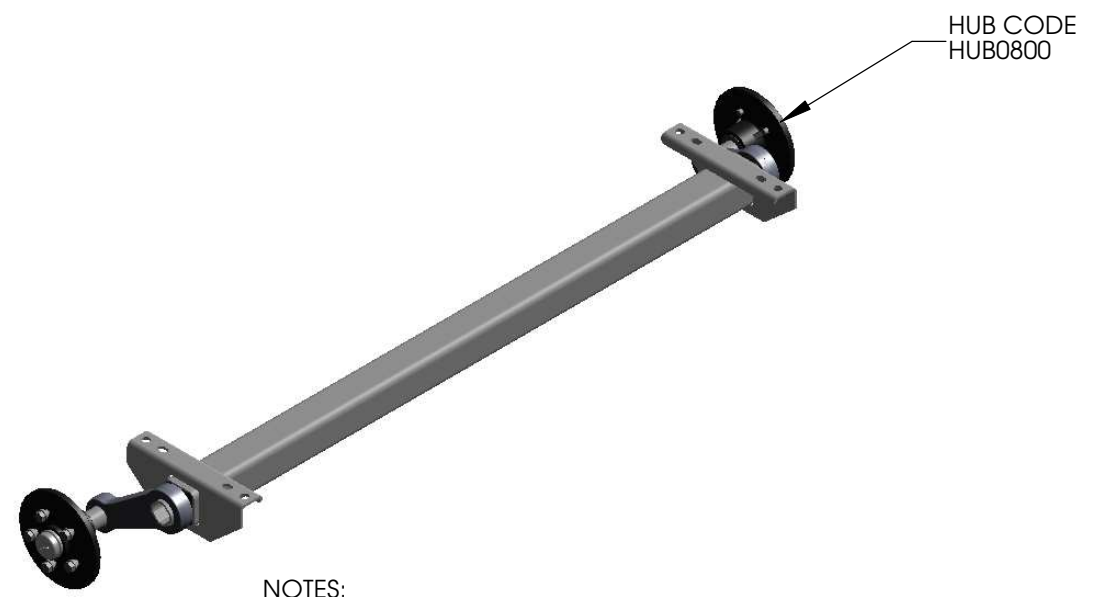

NOTES:

- 1 STANDARD TOE IN IS BETWEEN 0.2° & 0.6°
STANDARD CAMBER IS BETWEEN -0.6° TO -1.4°
- 2 TANDEM TOE IN IS 0°
TANDEM CAMBER IS -0.6° TO -1.4°

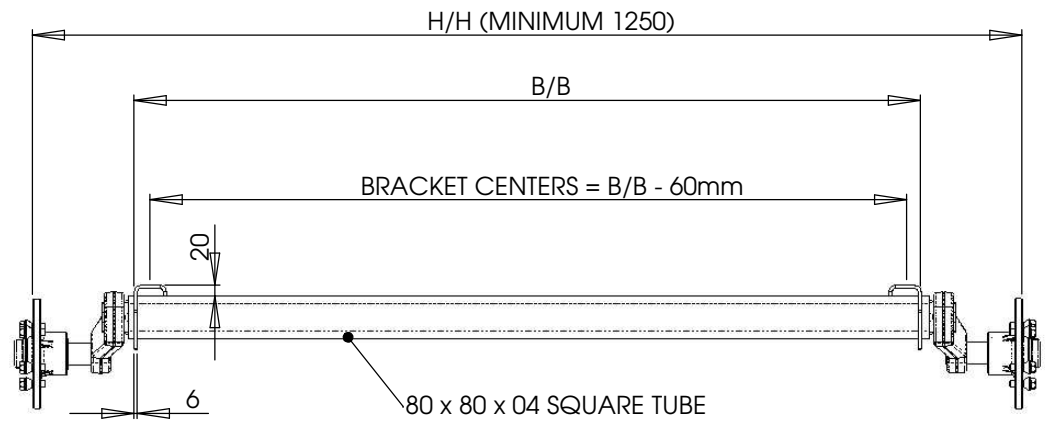

© COPYRIGHT **BURQUIP** INTERNATIONAL (Pty) Ltd

ASSUME A TOLERANCE OF ±1mm FOR DIMENSIONS WITHOUT TOLERANCES ALL DIMENSIONS IN mm UNLESS OTHERWISE SHOWN

TITLE:

PRODUCT: **AR0900/1150-1**

SCALE: 1:5 SHEET: A3

DRAWN BY: HILTON MILLWARD

DATE: 2007-06-27

BURQUIP

DRAWING NO. **AR0900-1150-1**

SHEET 1 of 1

REV **P1**

REV	DESCRIPTION OF CHANGE	ZONE	AUTH NO.	BY	DATE
P1	RELEASED				