

EST MASS: TOT SURFACE AREA:

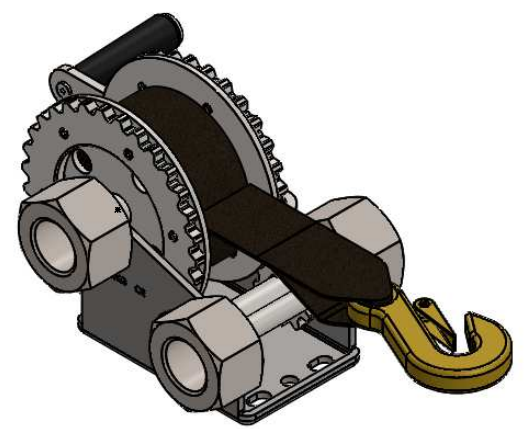
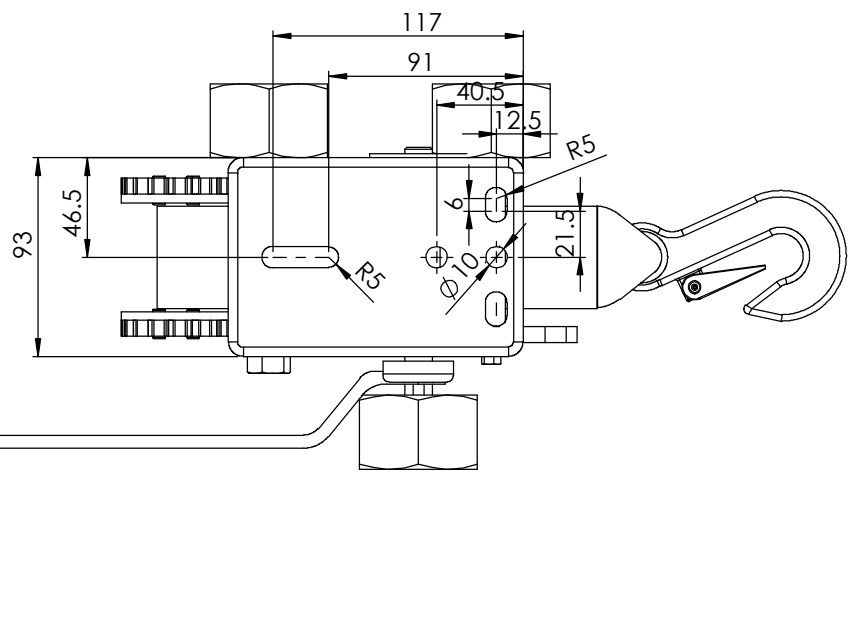
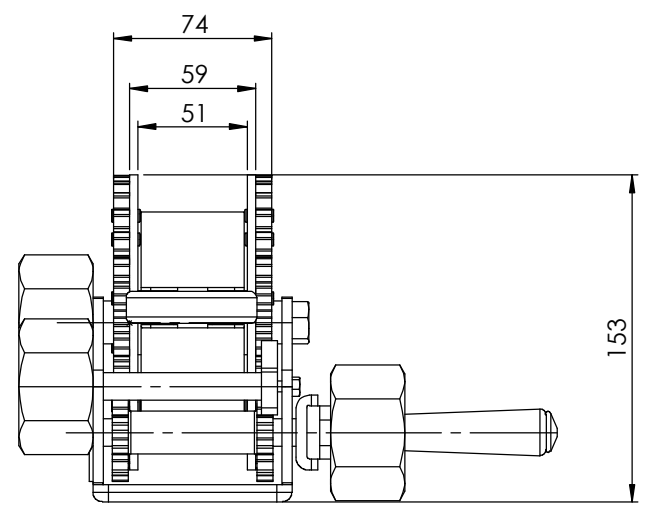
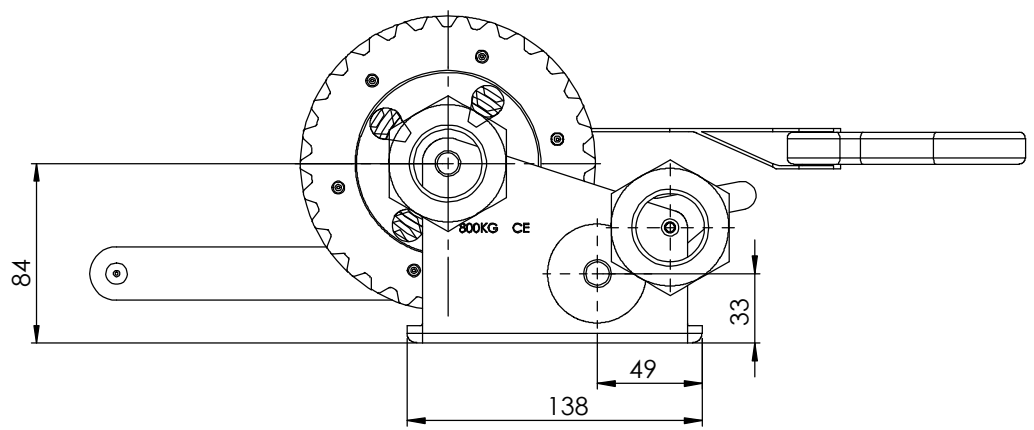

© COPYRIGHT BURQUIP INTERNATIONAL (Pty) Ltd

TITLE:

ASSUME A TOLERANCE OF ±1mm FOR DIMENSIONS WITHOUT TOLERANCES ALL DIMENSIONS IN mm UNLESS OTHERWISE SHOWN

PRODUCT: **HAND WINCH 800KG (DOUBLE GEAR)**

BURQUIP

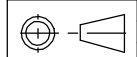

SCALE: 1:5 SHEET: A3
DRAWN BY: ARNOLD KABUYA
DATE: 2019-01-30

DRAWING NO. **HW1760**

REV **P1**

REV	DESCRIPTION OF CHANGE	ZONE	AUTH NO.	BY	DATE
P1	RELEASED				