

SECTION B-B

ITEM NO.	PART NUMBER	DESCRIPTION	QTY.
1	ABB3500-70-1965		1
2	BPF310B-70		2
3	M36CN2	CASTLE NUT	2
4	GCAP85-1	GREASE CAP ø85mm	2
5	ABSR80X160X5		2
6	ABSP01		2
7	ABSS01		2
8	BB310X80L		1
9	M5X70SPB		2
10	M10X25SS		6
11	M10SW		6
12	M10N		6
13	HBB310-80-05		2
14	BCSB01		2
15	BB310X80R		1
16	BCSB03		2
17	BBP01R4		2
18	M12X35G		1
19	M12NY		1

© COPYRIGHT BURQUIP INTERNATIONAL (Pty) Ltd TITLE:

ASSUME A TOLERANCE OF ±1mm FOR DIMENSIONS WITHOUT TOLERANCES ALL DIMENSIONS IN mm UNLESS OTHERWISE SHOWN

PRODUCT: AXLE 3500KG ABS



SCALE: 1:2 SHEET: A3  
DRAWN BY: HILTON MILLWARD  
DATE: 2008-04-11

DRAWING NO. AFB70AS6-ABS  
SHEET 1 of 3  
REV P1

REV	DESCRIPTION OF CHANGE	ZONE	AUTH NO.	BY	DATE
P1	RELEASED				

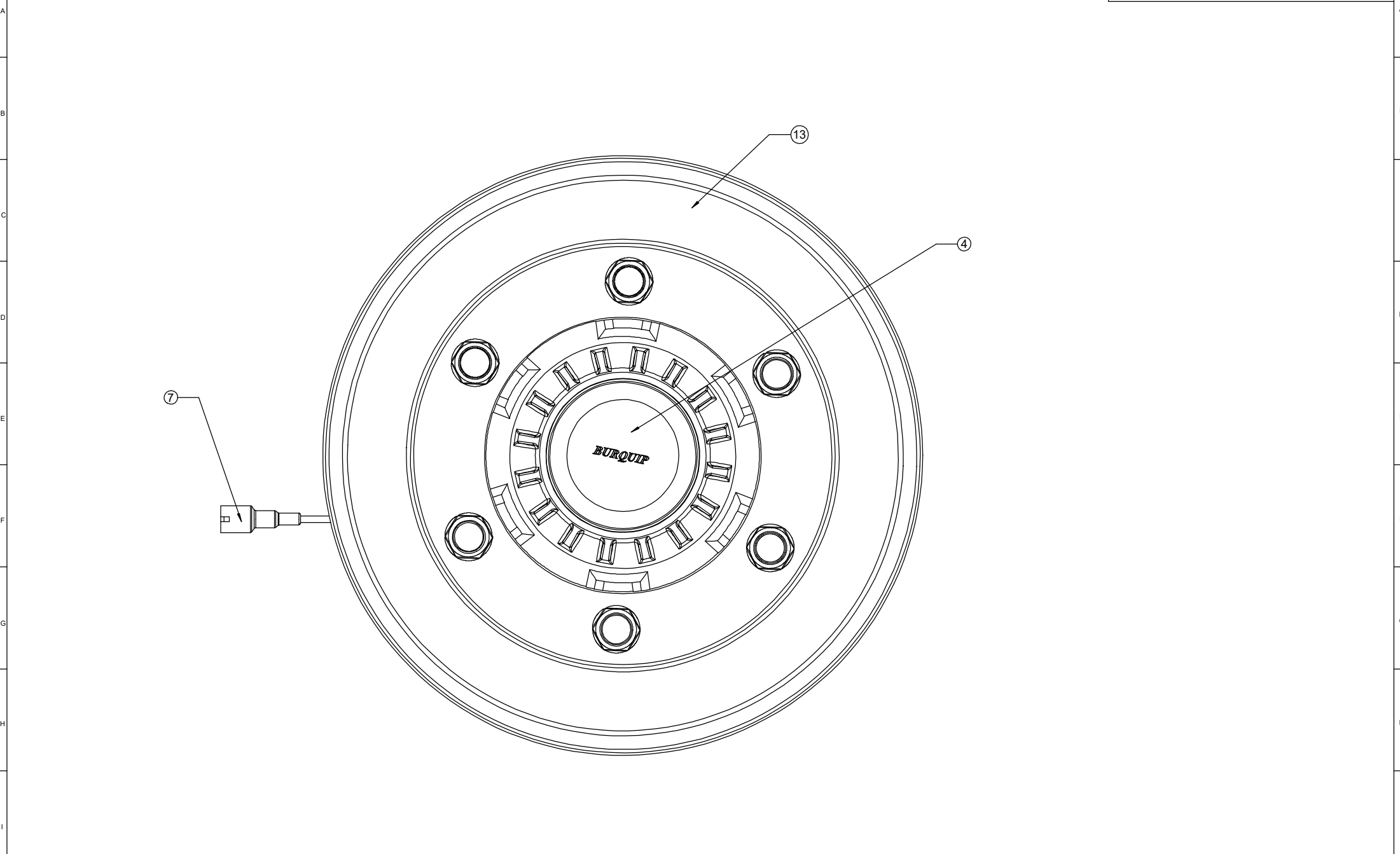

© COPYRIGHT **BURQUIP** INTERNATIONAL (Pty) Ltd

TITLE:

ASSUME A TOLERANCE OF ±1mm FOR DIMENSIONS WITHOUT TOLERANCES ALL DIMENSIONS IN mm UNLESS OTHERWISE SHOWN

PRODUCT: **AXLE 3500KG ABS**

**BURQUIP**

REV	DESCRIPTION OF CHANGE	ZONE	AUTH NO.	BY	DATE
P1	RELEASED				

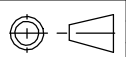

SCALE: 1:2 SHEET: A3  
 DRAWN BY: HILTON MILLWARD  
 DATE: 2008-04-11

DRAWING NO. **AFB70AS6-ABS**

REV **P1**

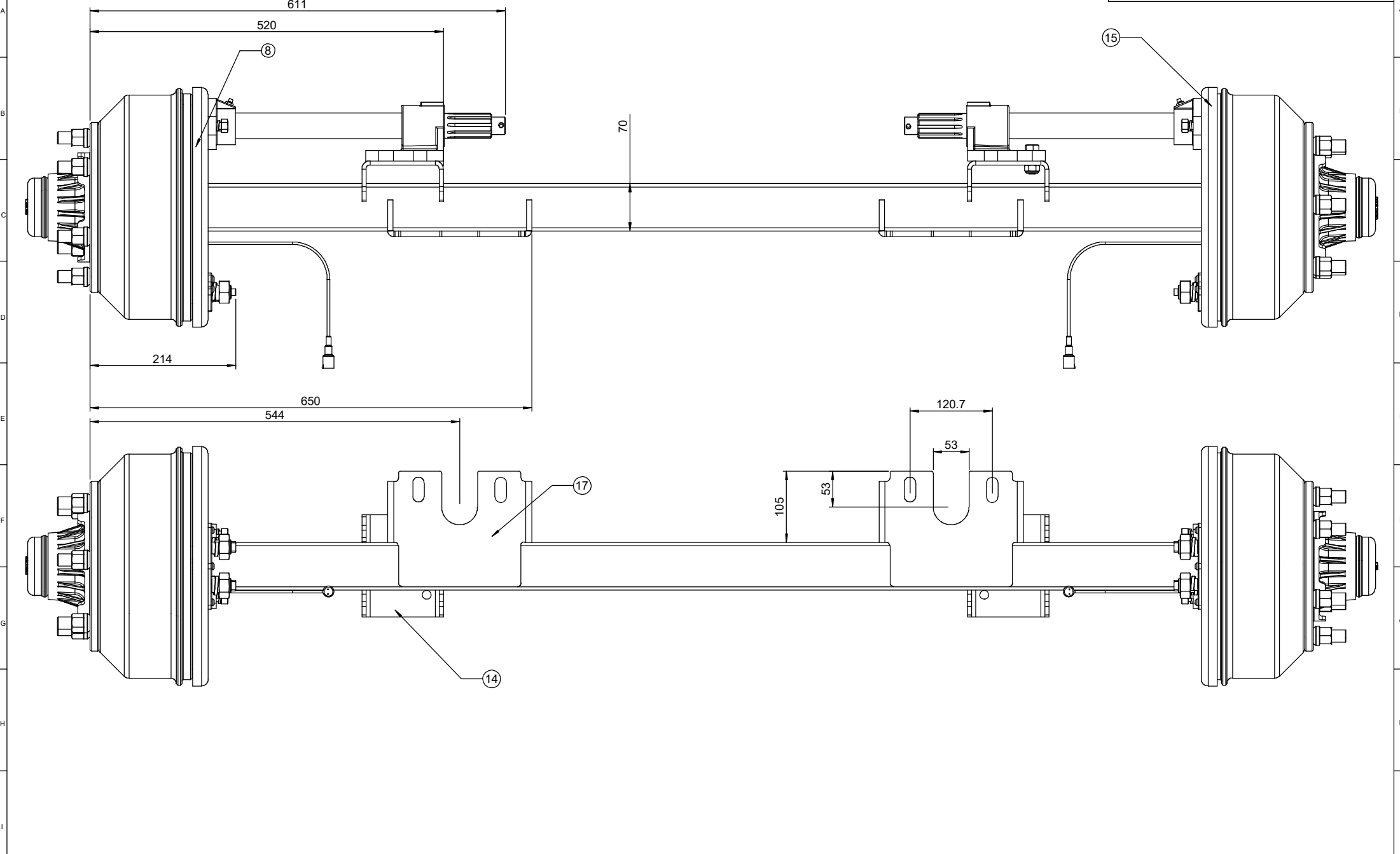

© COPYRIGHT BURQUIP INTERNATIONAL (Pty) Ltd

TITLE:

ASSUME A TOLERANCE OF ±1mm FOR DIMENSIONS WITHOUT TOLERANCES ALL DIMENSIONS IN mm UNLESS OTHERWISE SHOWN

PRODUCT: **AXLE 3500KG ABS**

**BURQUIP**

REV	DESCRIPTION OF CHANGE	ZONE	AUTH NO.	BY	DATE
P1	RELEASED				

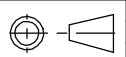

SCALE: 1:2 SHEET: A3  
DRAWN BY: HILTON MILLWARD  
DATE: 2008-04-11

DRAWING NO. **AFB70AS6-ABS**

REV **P1**