

NOTES:

- 1 STANDARD TOE IN IS BETWEEN 0.2° & 0.6°
STANDARD CAMBER IS BETWEEN -0.6° TO -1.4°
- 2 TANDEM TOE IN IS 0°
TANDEM CAMBER IS -0.6° TO -1.4°

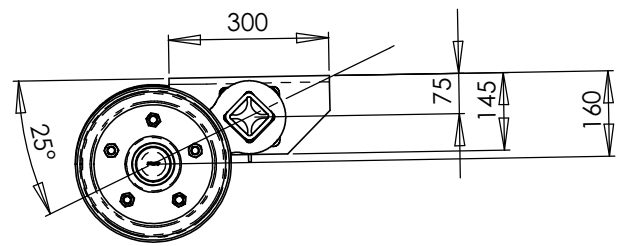

STANDARD ANGLE 25°
OPTIONAL 45°, 15°, 0°
-45°, -25°, -15°

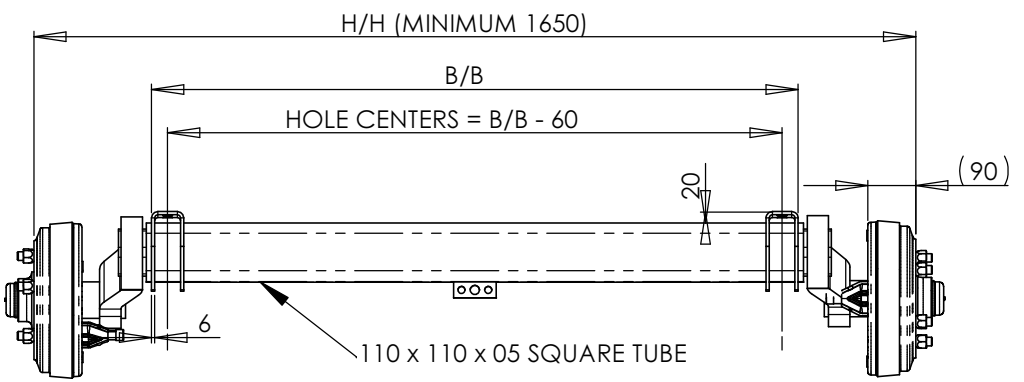

REV	DESCRIPTION OF CHANGE	ZONE	AUTH NO.	BY	DATE
P3	ADDED DROP ARM ANGLE OPTIONS			H.M.	H.M. 2014-08-05
P2	ADDED COMPLETE 250mm BRAKE ASSEMBLIES SBG250L AND SBG250R			H.M.	H.M. 2010-04-21
P1	RELEASED			H.M.	H.M.

© BURQUIP INTERNATIONAL (Pty) Ltd

ASSUME A TOLERANCE OF ±1mm FOR DIMENSIONS WITHOUT TOLERANCES ALL DIMENSIONS IN mm UNLESS OTHERWISE SHOWN

MATERIAL DESCRIPTION		MATERIAL SIZE	
TITLE:			
PRODUCT: ARC2000/2500-1		BURQUIP	
SCALE: 1:10	SHEET: A3	DRAWING NO.	REV
DRAWN BY: HILTON MILLWARD		ARC2000-2500-1	P3
DATE: 2007-06-15			