

STANDARD ANGLE 25°
 OPTIONAL 45°, 15°, 0°
 -45°, -25°, -15°

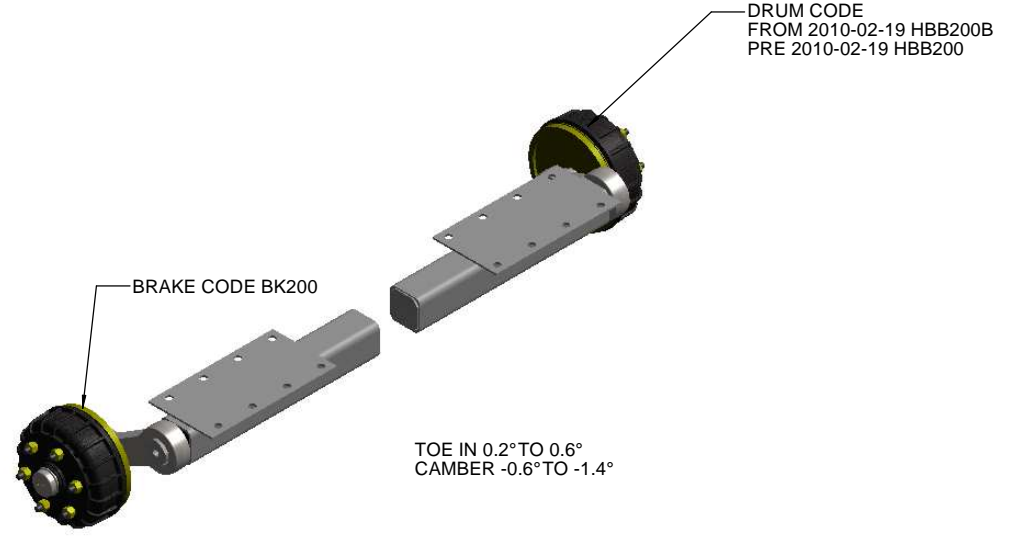

© COPYRIGHT BURQUIP INTERNATIONAL (Pty) Ltd

TITLE: **ARC1200/1600 STUB PR**

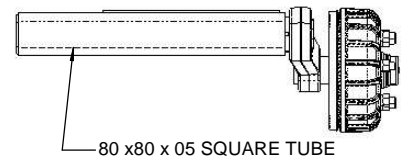
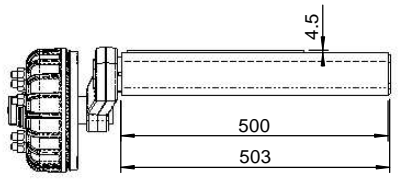

ASSUME A TOLERANCE OF ±1mm FOR DIMENSIONS WITHOUT TOLERANCES ALL DIMENSIONS IN mm UNLESS OTHERWISE SHOWN

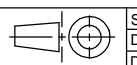

SCALE: 1:10 SHEET: A3
 DRAWN BY: HILTON MILLWARD
 DATE: 2007-01-01

DRAWING NO. **ARC1200-1600L&R**

REV **P2**

REV	DESCRIPTION OF CHANGE	ZONE	AUTH NO.	BY	DATE
P2	CHANGED DRUM CODE FROM HBB200 SERIES TO HBB200B SERIES			H.M.	2010-02-19
P1	RELEASED			H.M.	